



SW3108G

User Manual

1. Specification

Model	SW3108G Industrial-grade 8 ports Ethernet Switch
Ethernet Ports	8* 10/100/1000 Base-T(X)
	RJ45 port supports full-duplex/half-duplex and MDI/MDI-X auto-negotiation.
Power	DC Model: DC 9~60V (Supports dual power redundancy, non-polarized input)
Consumption	<2.5W (@12VDC)
IEE Standard	IEEE802.3, 802.3u, 802.3x, 802.3ab, 802.3z
Switching mode	Store -Forward
Backplane Bandwidth	16Gbps
Buffer Size	1.5Mbit
MAC Address	4K
Dimension	140mm×35mm×100mm (excluding DIN rail and terminal blocks)
Operating Temperature	-40°C~+85°C
Storage Temperature	-40°C~+85°C
Humidity	5%~95%RH (non-condensing)
EMC	IEC61000-4-2 (ESD), Level 4 IEC61000-4-5(Surge), Level 4 ※ The ports support 6KV surge protection. IEC61000-4-4(EFT), Level 4 IEC61000-4-3 (RS) , Level 4 IEC61000-4-6 (CS) , Level 4

2. Hardware and Installation

❖ Cautions

To avoid damage to the device or personal injury due to improper use, please note the following:

1. Ensure the switch is powered off during installation.
2. Make sure the input voltage is within the range specified for the switch.
3. When connecting the power supply, ensure the power cord is properly connected to the power terminals before powering on.
4. When powering off, disconnect the power supply before removing the power cord.
5. Do not open the switch's casing.
6. Do not place heavy objects on the switch.
7. Keep the switch clean and do not use any liquids to clean it.

❖ Installation

1. Position the switch at an upward angle so that the upper hook on the back of the switch clips onto the top of the DIN rail.
2. Press the switch downward to secure the lower hook on the back of the switch into the DIN rail. Once clipped in, if there is no noticeable movement, the switch is securely installed.

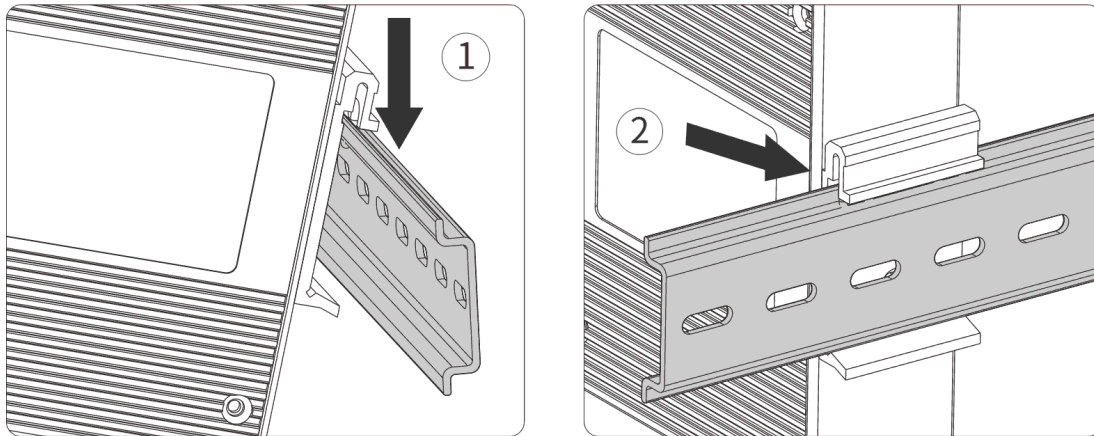

❖ **Power Input**

The series of 3/4/5 100Mbps ports industrial Ethernet switch provides a 5-position, 5.08mm-pitch industrial-grade terminal block as the power input interface. The connection method differences depending on the power input range:

- **DC Model:** Powered by DC 9~60V, supports dual power inputs with non-polarized input. V1 and V2 serve as backups for each other, and you can connect to either V1, V2, or both simultaneously.
- **AC Model:** Powered by AC 85~264V / DC 110~370V. Connect the power lines to the V1+ (L) and V1- (N) terminals only. Do not connect to the V2+ or V2- terminals. Please exercise caution to prevent electric shock.

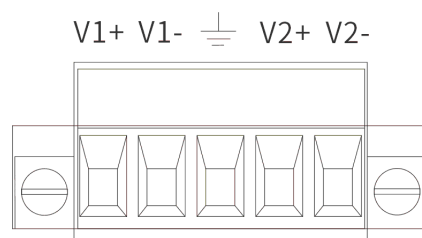

❖ **Ethernet**

The RJ45 port supports CAT-5 twisted pair cables and automatically recognizes straight-through and crossover cables, with a transmission distance of up to 100

meters. Users can connect their network devices (such as workstations, hubs, or switches) to the switch's RJ45 port using Cat5 twisted pair cables.

3. LED

❖ LED Indicator

LED Indicators		Status	Definitions
Power LED	P1/P2	Steady On	Power Supply is on normal
		Off	Disconnection or malfunction
RJ45 Port Indicator Light	SPD (Yellow LED)	Steady On	1000M Operating Status
		Off	10/100M Operating Status
RJ45 Port Indicator Light	L/A (Green LED)	Steady On	The RJ45 works as valid connection
		Flash	The RJ45 works transmitting and receiving data
		Off	The RJ45 port does not work.

4. Product Dimension

❖ Dimension

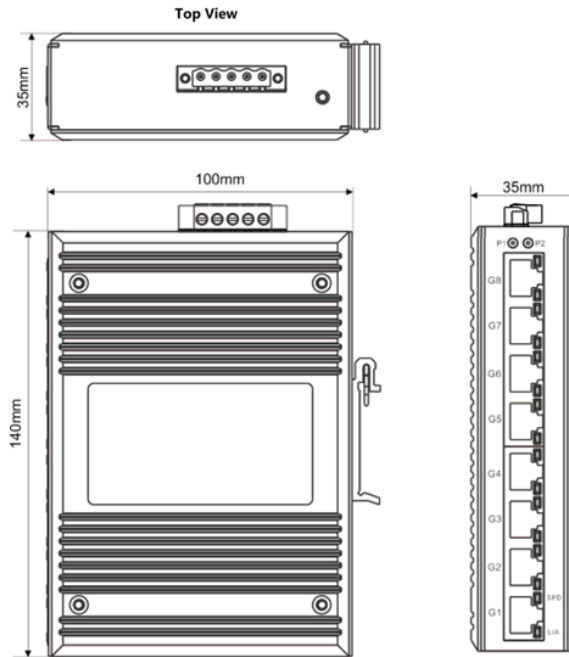

5. Package

❖ Packing

Item	Q'ty	Remark
Ethernet Switch device	1	
AC220V Power Cable	1	For AC type model
User Manual	1	Digital copy